

ALL UNITS IN INCHES UNLESS OTHERWISE STATED.

DOUBLE KNOCKOUTS ARE ON THE BOTTOM OF THE ENCLOSURE. THE DOUBLE KNOCKOUTS HAVE AN INNER DIAMETER OF $\varnothing 0.88$ IN AND AN OUTER DIAMETER OF $\varnothing 1.125$.

ALL OTHER KNOCKOUTS ARE SINGLE KNOCKOUTS. DIAMETERS ARE DIFFERENTIATED TO THE LEFT.

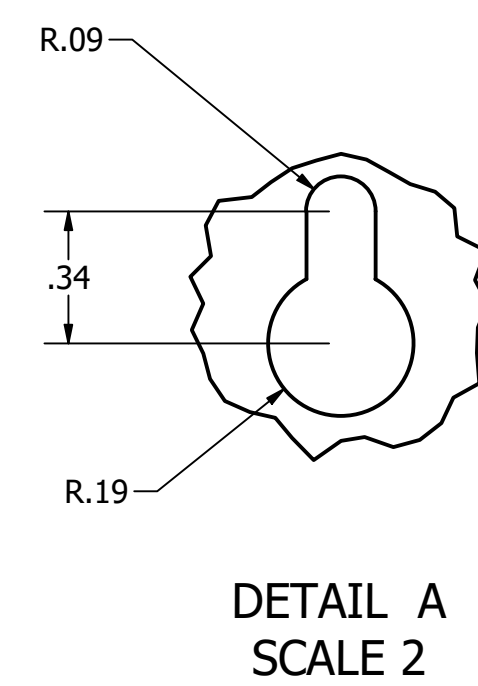

800-473-0213 | info@mierproducts.com | www.mierproducts.com



DRAWN Brock Borden	2/26/2020	Mier Products	
CHECKED		TITLE	
QA		BW-202	
MFG		SIZE D	DWG NO bw-202 box
APPROVED		SCALE 2/5	REV
		SHEET 1 OF 1	